

# Dual Aspect Home Improvements Ltd

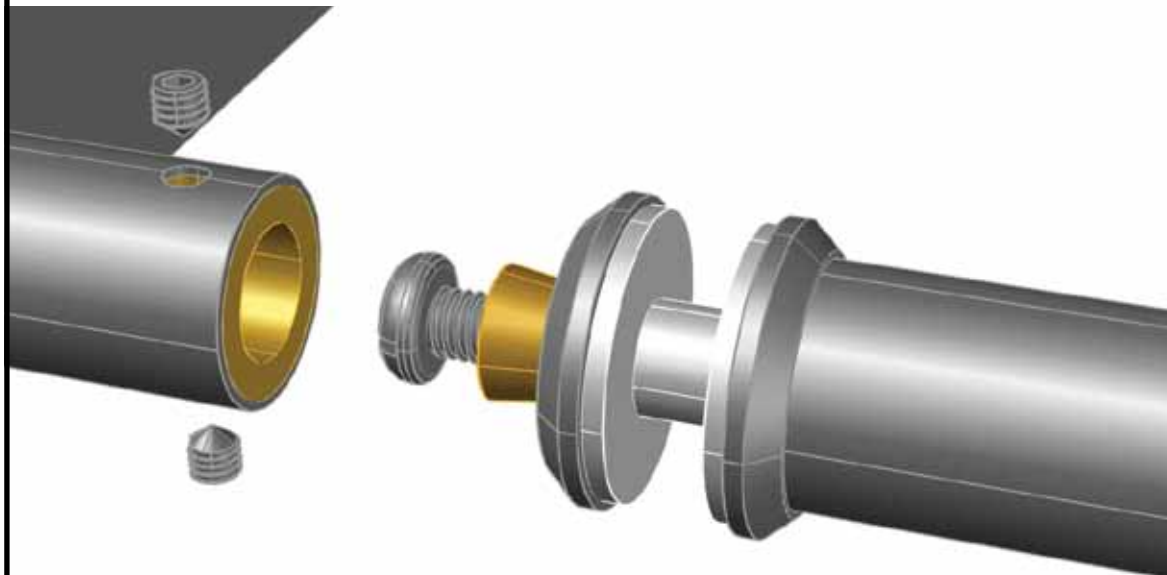

ITEM NO.	PART DESCRIPTION	QTY.	MATERIAL	FINISH
1	INTERNAL HANDLE	1	STAINLESS STEEL	BRUSHED
2	EXTERNAL HANDLE	1	STAINLESS STEEL	BRUSHED
3	BEVEL RING	4	STAINLESS STEEL	BRUSHED
4	INLINE LOCKING NUT	2	COPPER	RAW
5	CLEAR GASKET	4	NYLON	RAW
6	SPACER RING	2	NYLON	RAW
7	HANDLE FIXING SCREWS	2	STAINLESS STEEL	RAW
8	SCREW CHAMBER	2	COPPER	RAW
9	CLAMPING SCREWS	4	STAINLESS STEEL	RAW

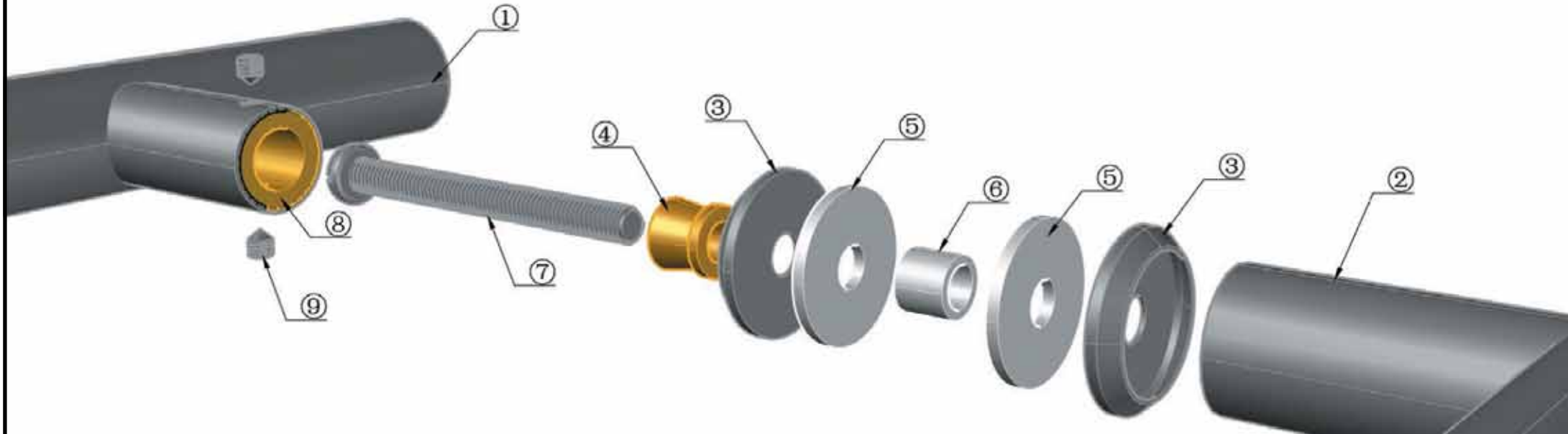

01303 267805

orders@dualhomeimprovements.com

**M001851**

1200mm Inline Round

Back to back

Weight 2.75kg

# Dual Aspect Home Improvements Ltd

INTERNAL

EXTERNAL

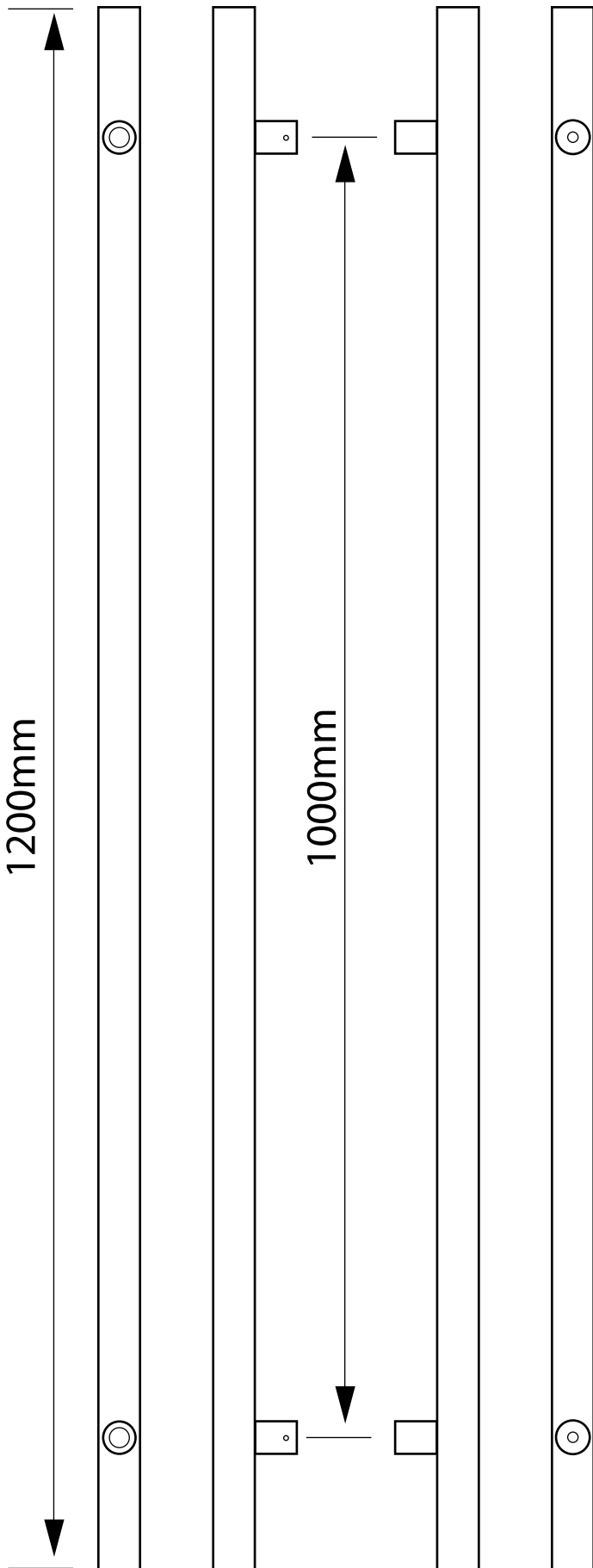

SCALE 1:5

INTERNAL

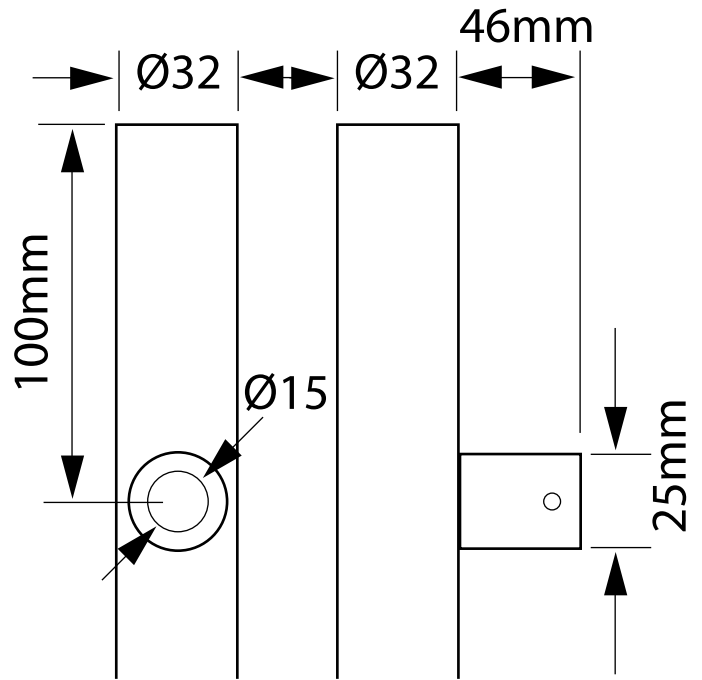

SCALE 1:2

EXTERNAL

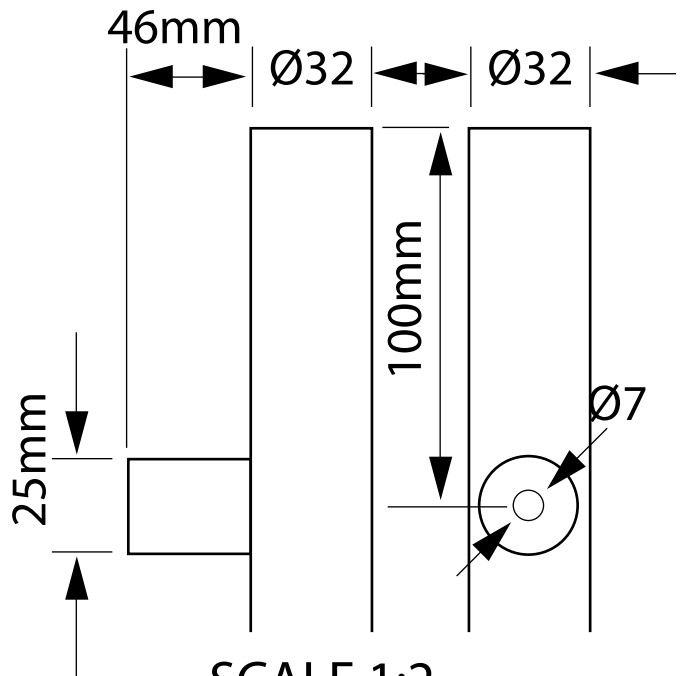

SCALE 1:2



01303 267805

orders@dualhomeimprovements.com

1200mm Inline Round

Back to back

Weight 2.75kg

**M001851**

**Item 3 Bevel Ring**

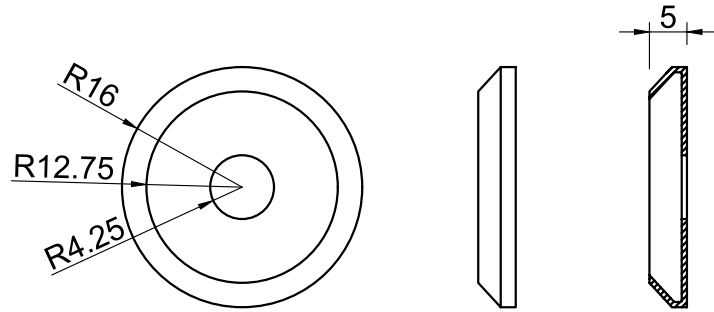

**Item 4 Inline Locking Nut**

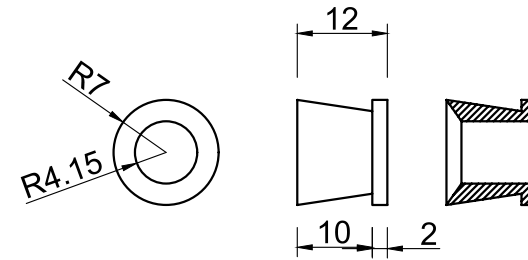

**Item 5 Gasket**

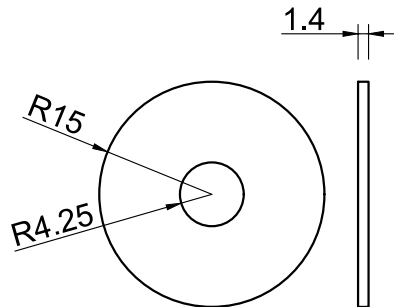

**Item 6 Spacer Ring**

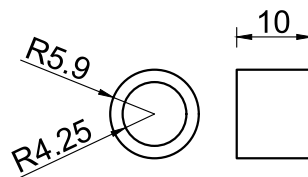

**Item 7 Inline Handle Fixing Screws**

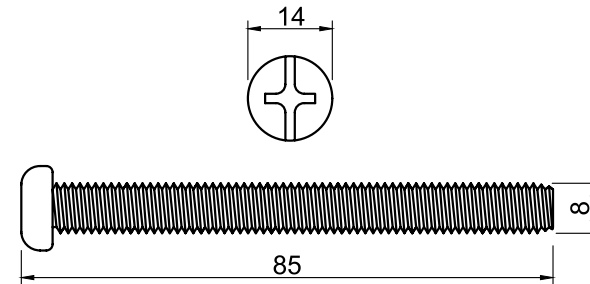

**Scale 1:1**



01303 267805  
orders@dualhomeimprovements.com

1200mm Inline Round

Back to back

Weight 2.75kg

**M001851**