

Dual Aspect Home Improvements Ltd

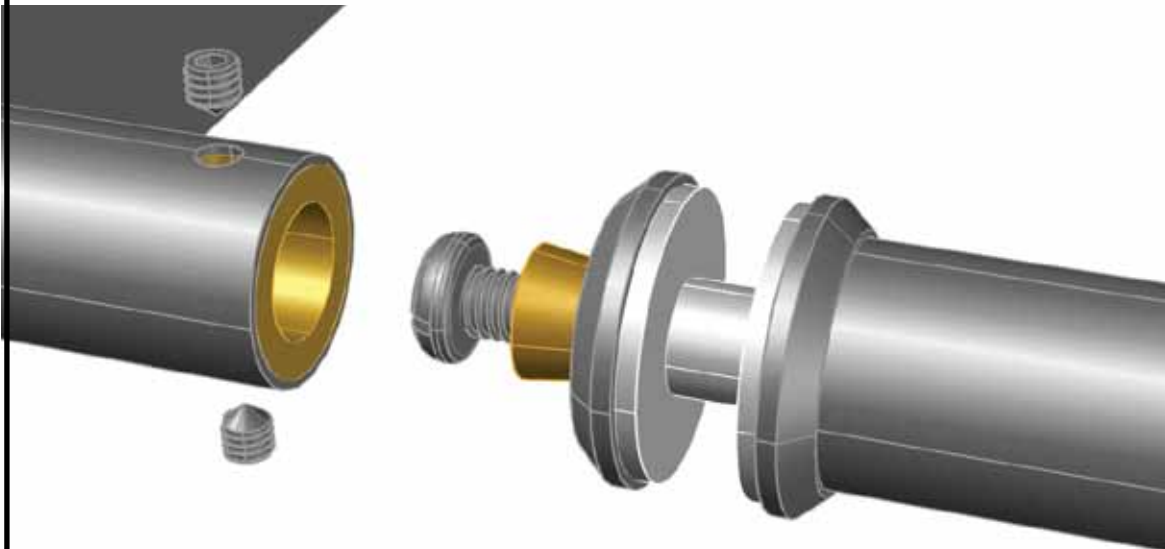

ITEM NO.	PART DESCRIPTION	QTY.	MATERIAL	FINISH
1	INTERNAL HANDLE	1	STAINLESS STEEL	BRUSHED
2	EXTERNAL HANDLE	1	STAINLESS STEEL	BRUSHED
3	BEVEL RING	4	STAINLESS STEEL	BRUSHED
4	INLINE LOCKING NUT	2	COPPER	RAW
5	CLEAR GASKET	4	NYLON	RAW
6	SPACER RING	2	NYLON	RAW
7	HANDLE FIXING SCREWS	2	STAINLESS STEEL	RAW
8	SCREW CHAMBER	2	COPPER	RAW
9	CLAMPING SCREWS	4	STAINLESS STEEL	RAW

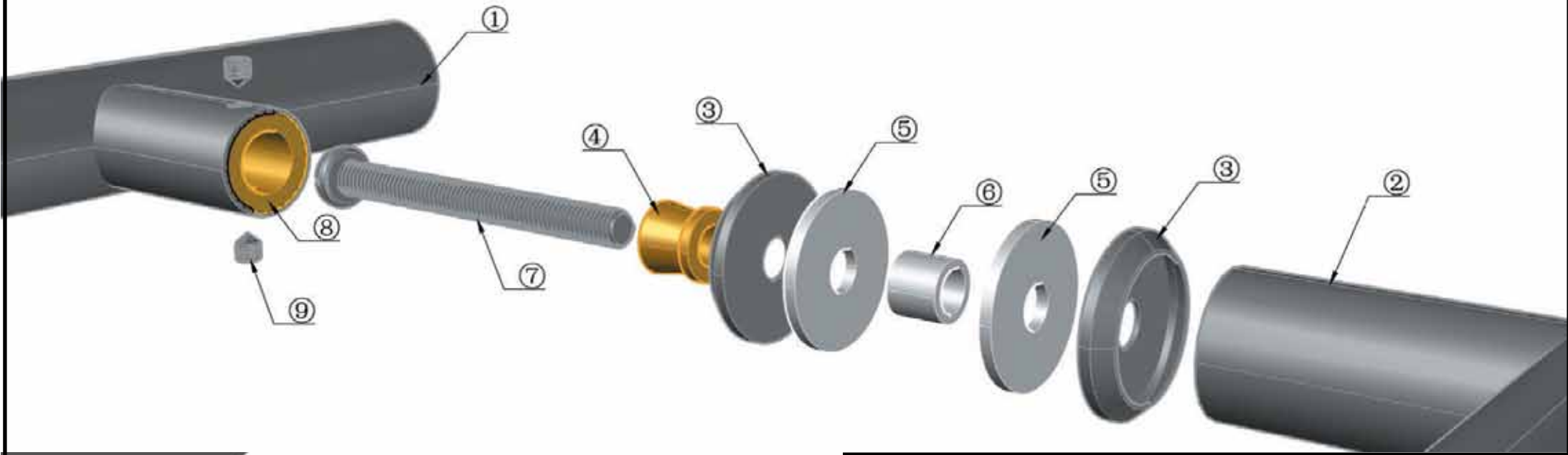

01303 267805

orders@dualhomeimprovements.com

M001915

1500mm Inline Round

Back to back

Weight 3.25kg

INTERNAL

EXTERNAL

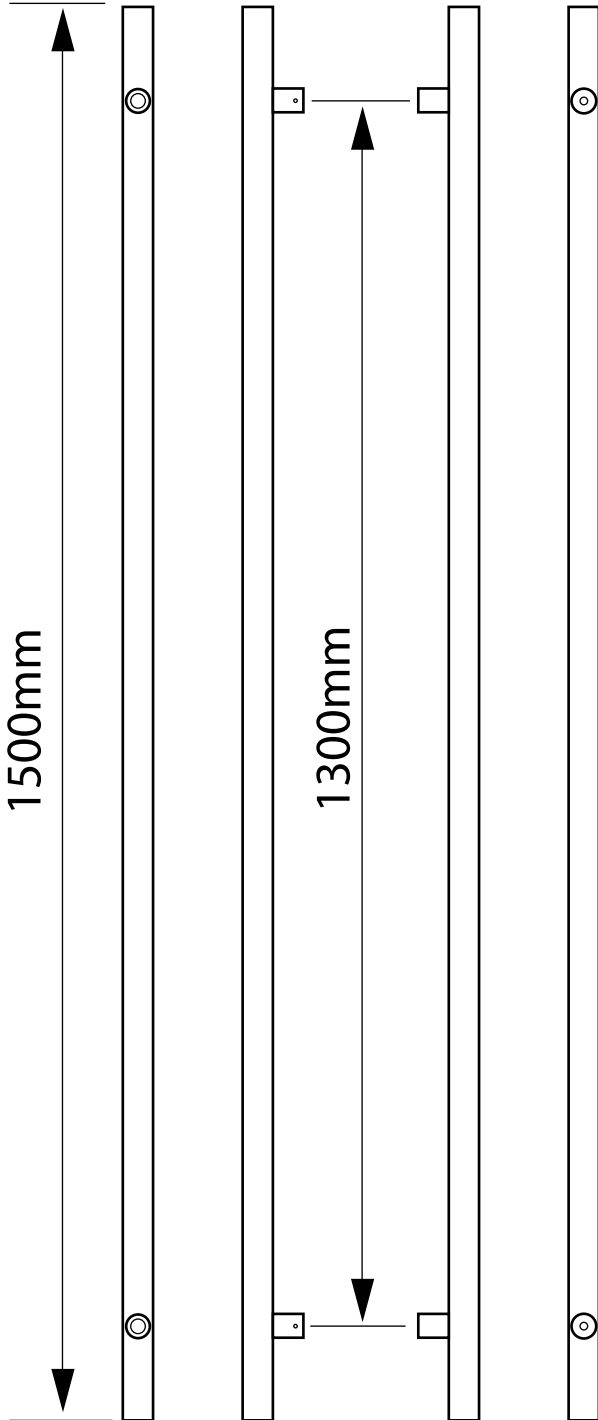

SCALE 1:8

INTERNAL

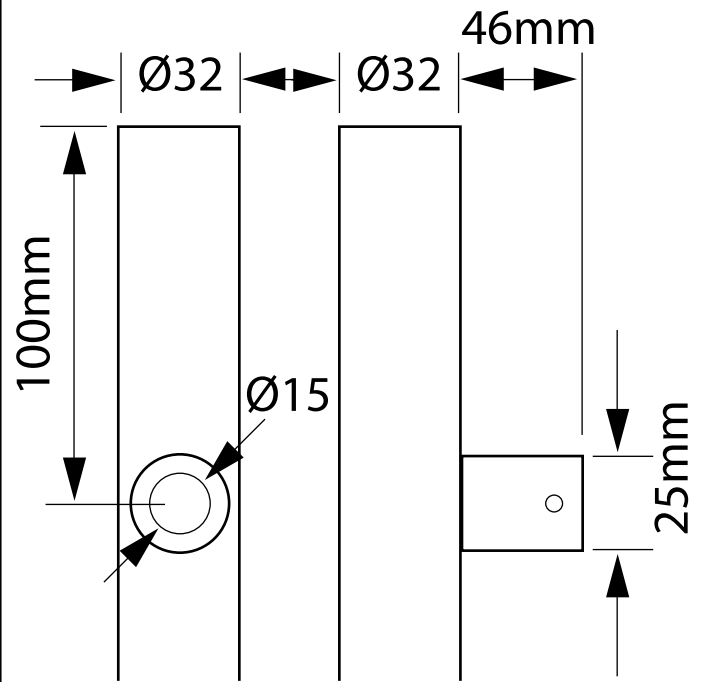

SCALE 1:2

EXTERNAL

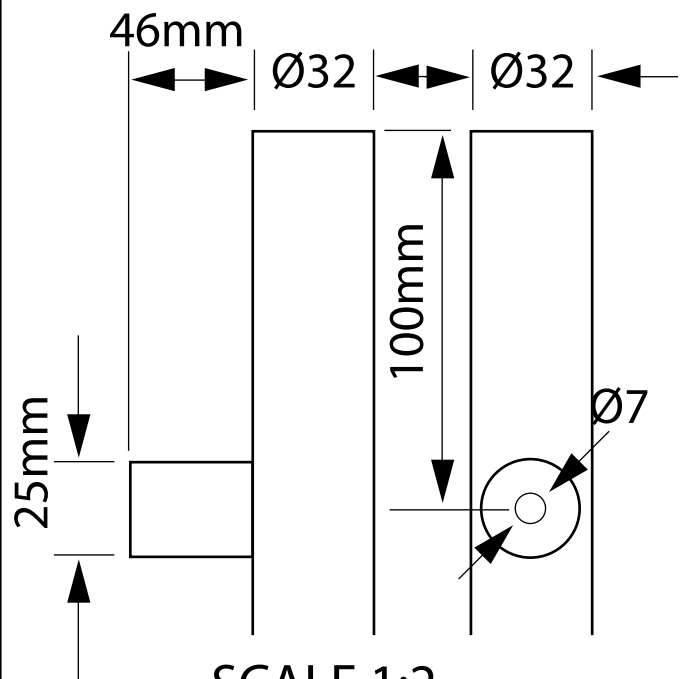

SCALE 1:2



01303 267805

orders@dualhomeimprovements.com

1500mm Inline Round

Back to back

Weight 3.25kg

M001915

Item 3 Bevel Ring

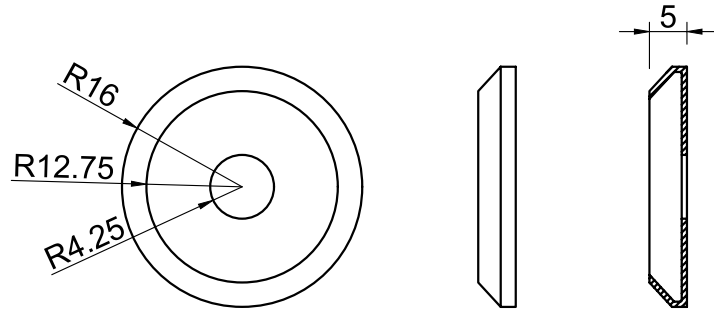

Item 4 Inline Locking Nut

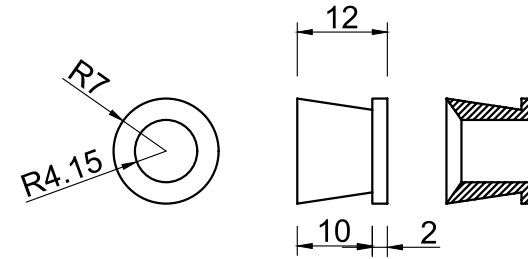

Item 5 Gasket

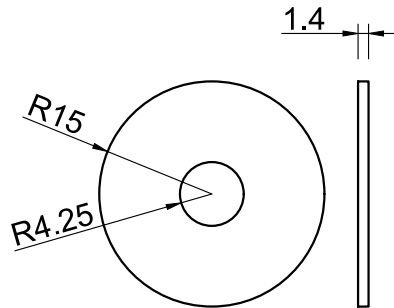

Item 6 Spacer Ring

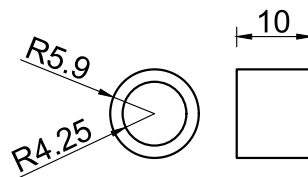

Item 7 Inline Handle Fixing Screws

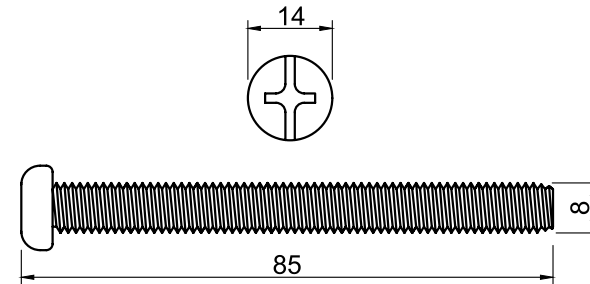

Scale 1:1



01303 267805

orders@dualhomeimprovements.com

1500mm Inline Round

Back to back

Weight 3.25kg

M001915