

# Dual Aspect Home Improvements Ltd

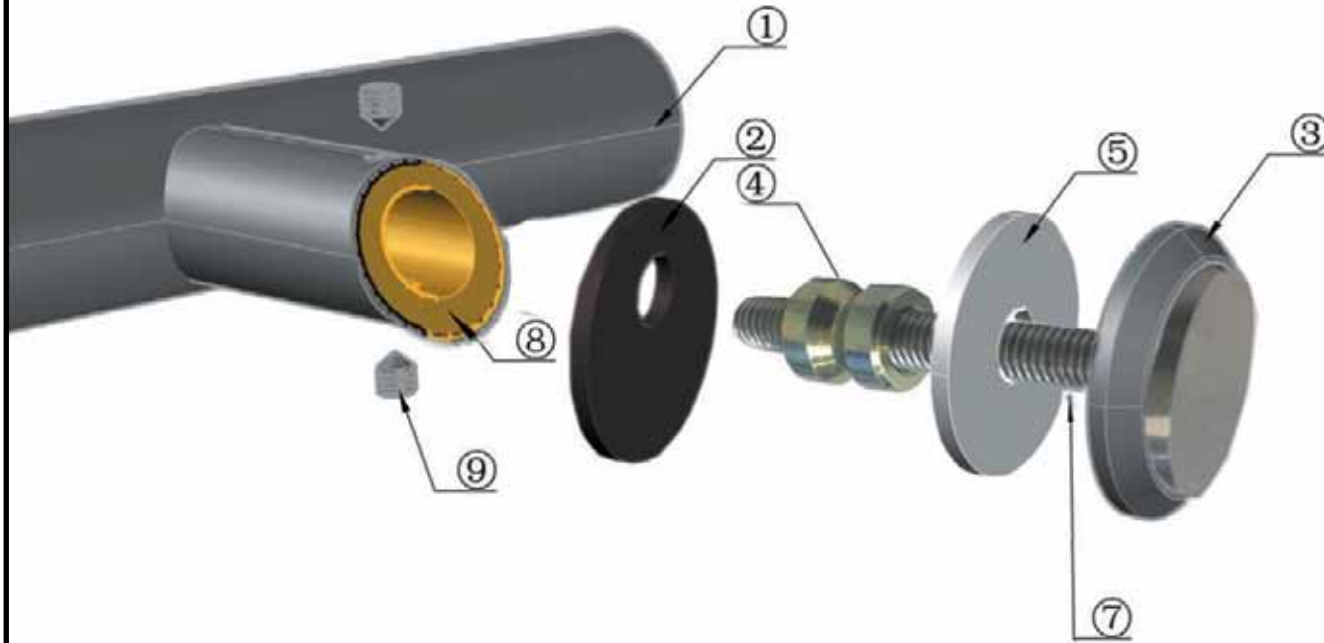

ITEM NO.	PART DESCRIPTION	QTY.	MATERIAL	FINISH
1	INTERNAL HANDLE	1	STAINLESS STEEL	BRUSHED
2	OFFSET BLACK GASKET	2	NYLON	RAW
3	BEVEL RING	2	STAINLESS STEEL	BRUSHED
4	SINGLE SIDED LOCKING NUT	2	STAINLESS STEEL	RAW
5	CLEAR GASKET	2	NYLON	RAW
6				
7	HANDLE FIXING SCREWS	2	STAINLESS STEEL	RAW
8	SCREW CHAMBER	2	COPPER	RAW
9	CLAMPING SCREWS	4	STAINLESS STEEL	RAW



01303 267805

orders@dualhomeimprovements.com

**M002291**

1200mm Offset Round

Single

Weight 1.375kg

EXTERNAL

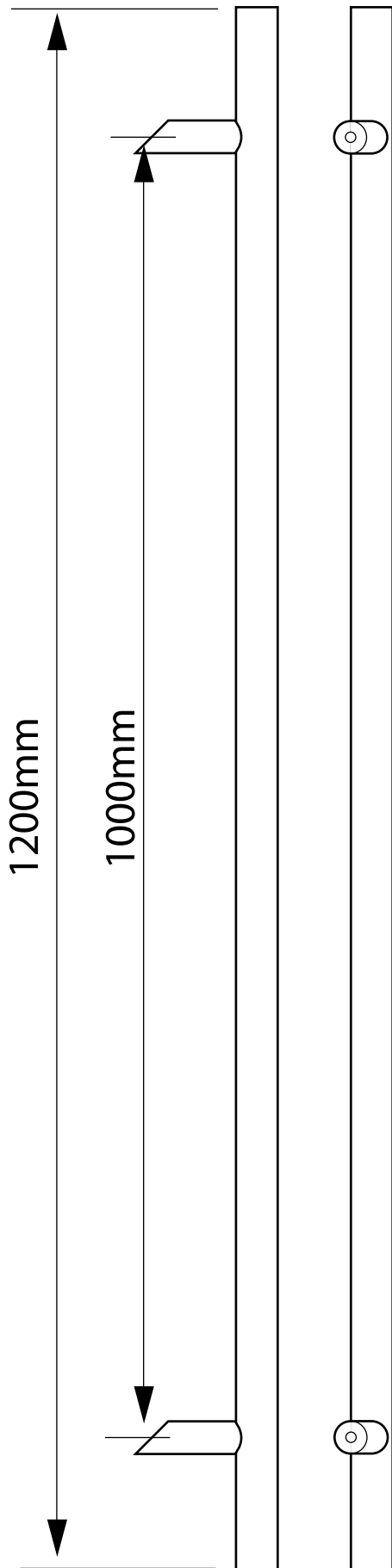

SCALE 1:5

EXTERNAL

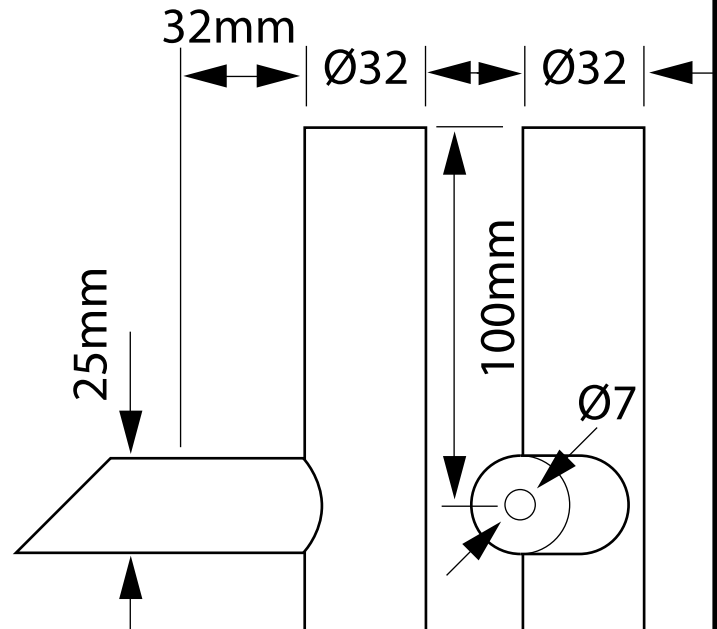

SCALE 1:2



01303 267805  
orders@dualhomeimprovements.com

1200mm Offset Round

Single

Weight 1.375kg

**M002291**

Item 3 Bevel Ring

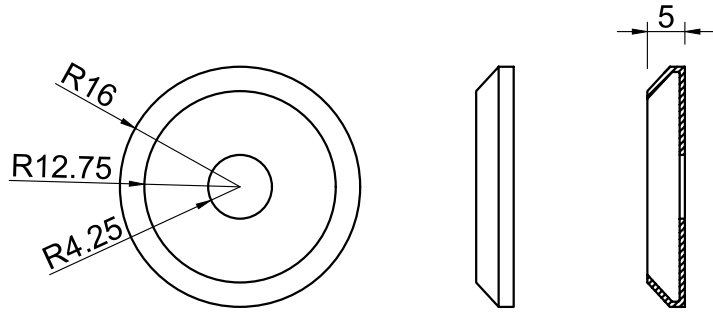

Item 4 Locking Nut

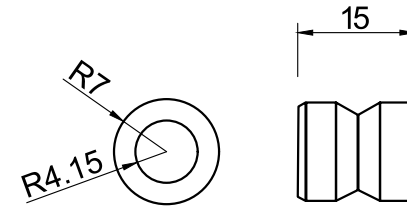

Item 5 Offset Gasket

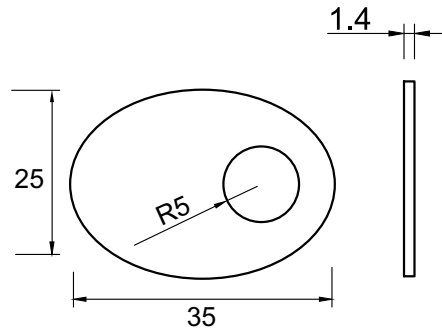

Item 7 Offset Handle Fixing Screws

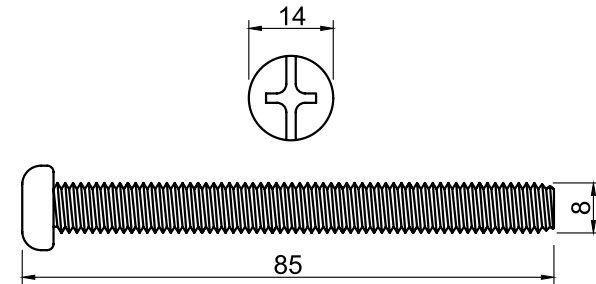

Scale 1:1



01303 267805

orders@dualhomeimprovements.com

1200mm Offset Round

Single

Weight 1.375kg

**M002291**