

# Dual Aspect Home Improvements Ltd

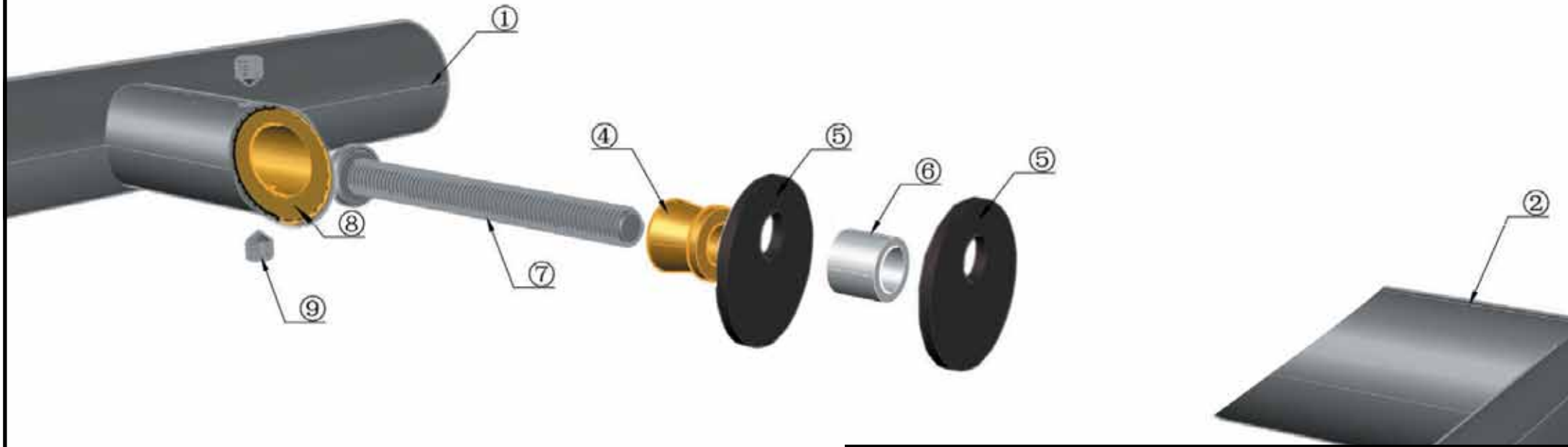

ITEM NO.	PART DESCRIPTION	QTY.	MATERIAL	FINISH
1	INTERNAL HANDLE	1	STAINLESS STEEL	BRUSHED
2	EXTERNAL HANDLE	1	STAINLESS STEEL	BRUSHED
3				
4	OFFSET LOCKING NUT	2	COPPER	RAW
5	OFFSET BLACK GASKET	4	NYLON	RAW
6	SPACER RING	2	NYLON	RAW
7	HANDLE FIXING SCREWS	2	STAINLESS STEEL	RAW
8	SCREW CHAMBER	2	COPPER	RAW
9	CLAMPING SCREWS	4	STAINLESS STEEL	RAW



01303 267805

orders@dualhomeimprovements.com

**M001917**

1200mm Offset Round

Back to back

Weight 2.75kg

INTERNAL

EXTERNAL

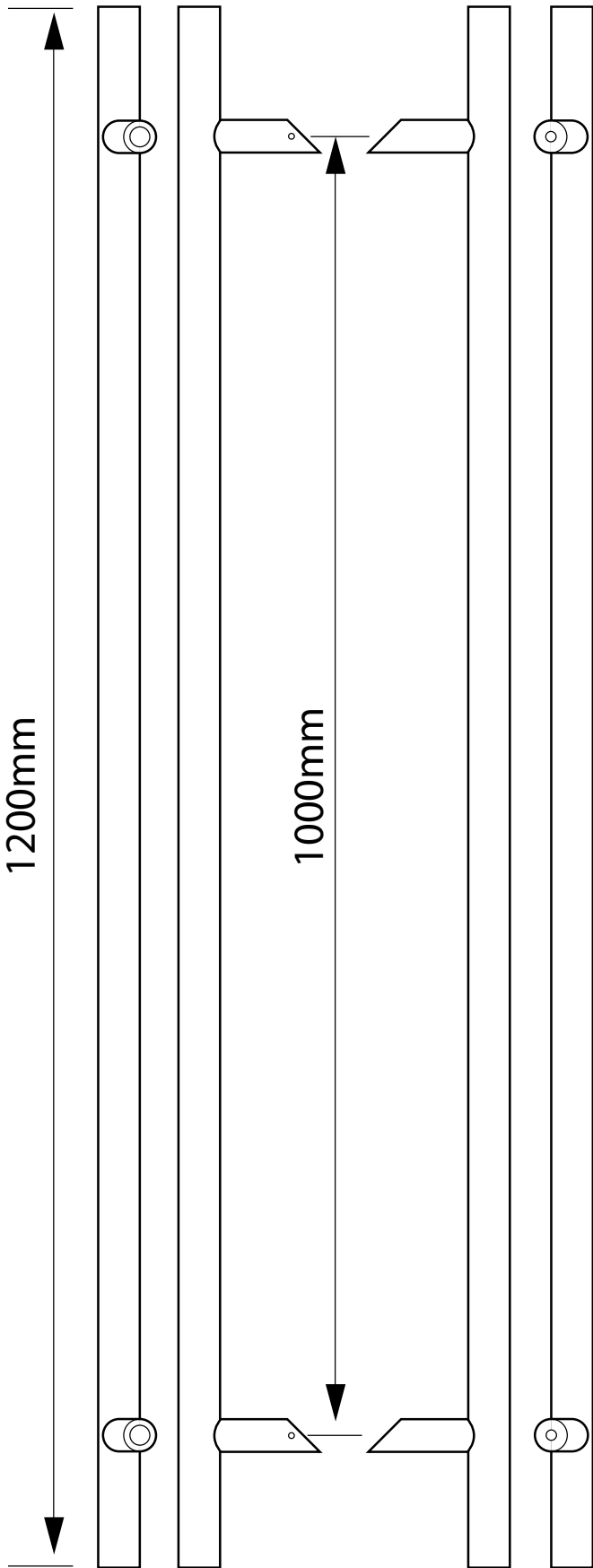

SCALE 1:5

INTERNAL

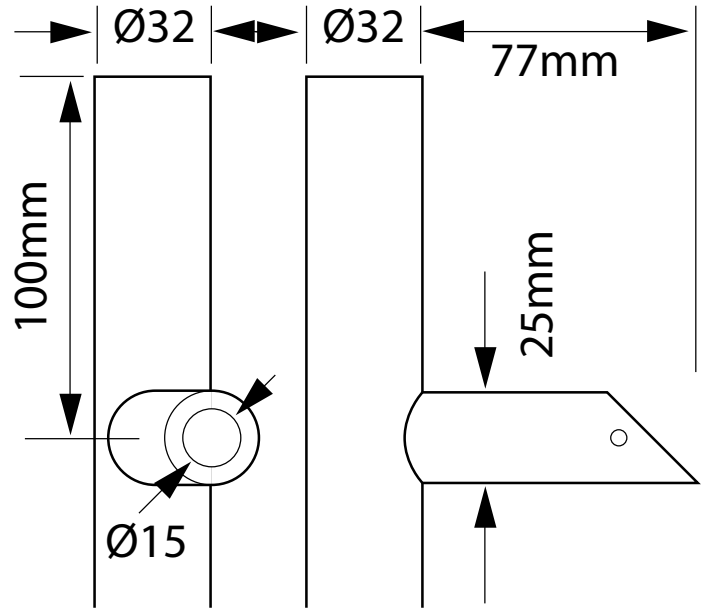

SCALE 1:2

EXTERNAL

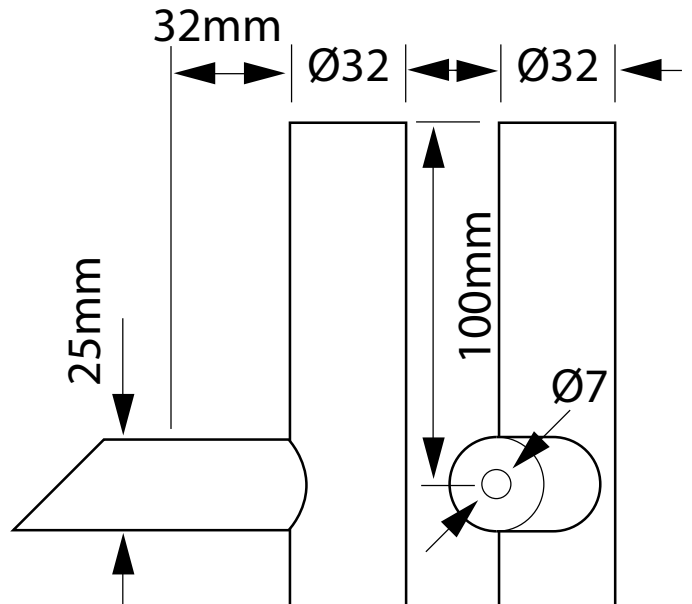

SCALE 1:2



01303 267805

orders@dualhomeimprovements.com

1200mm Offset Round

Back to back

Weight 2.75kg

**M001917**

## Item 4 Offset Locking Nut

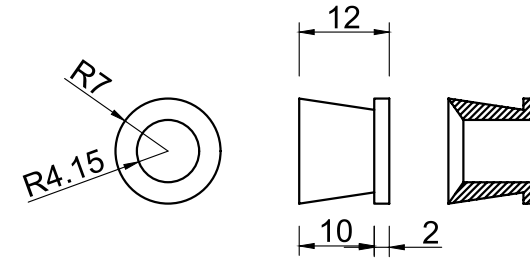

## Item 5 Offset Gasket

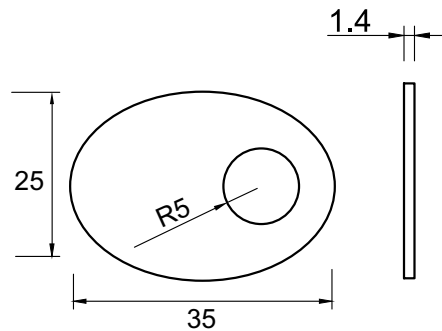

## Item 6 Spacer Ring

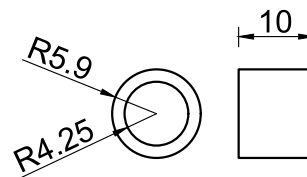

## Item 7 Offset Handle Fixing Screws

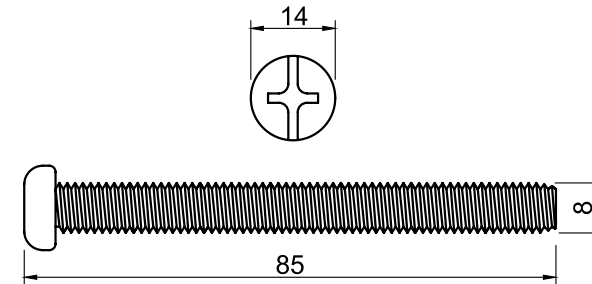

Scale 1:1



01303 267805

orders@dualhomeimprovements.com

1200mm Offset Round

Back to back

Weight 2.75kg

**M001917**